

TORQUE ACTUATORS APPLICATION SHEET



CUSTOMER	
Name	Phone
Address	E-mail

APPLICATION DESCRIPTION

Please indicate technical data and binding dimension in order to meet your application needs

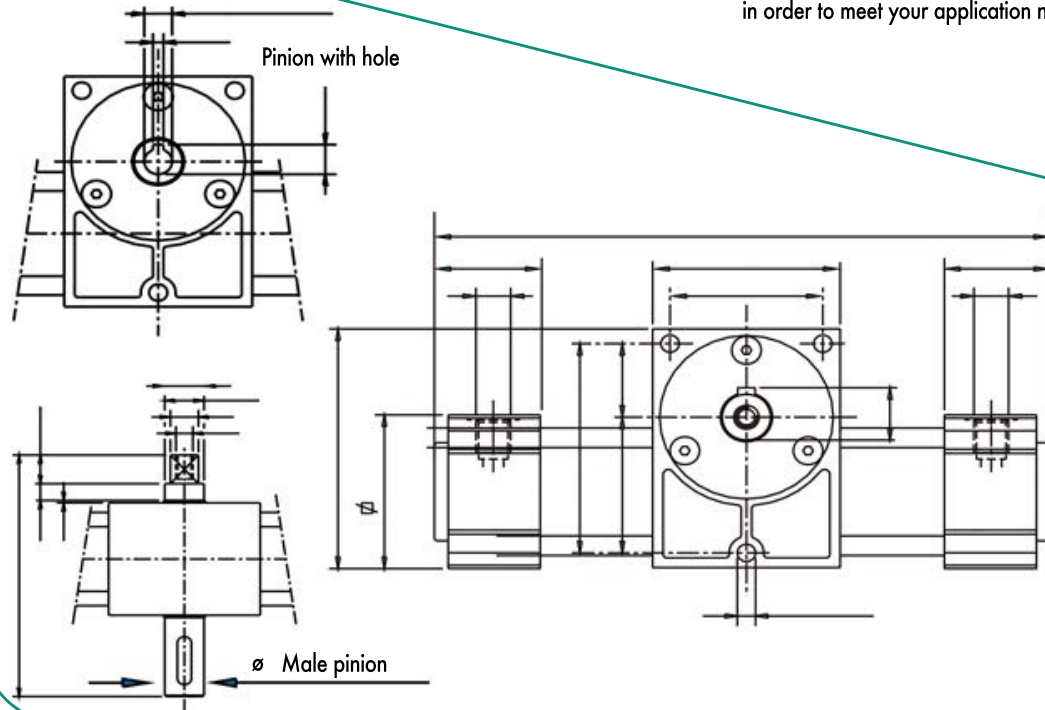

QUANTITY

Order _____
 Yearly _____

TECHNICAL DATA

Bore _____
 Rotation _____

SEALS
 NBR PUR FKM

WORKING PRESSURE min _____
 max _____

WORKING TEMPERATURE min _____
 max _____

CYCLE RATE min _____
 max _____

TORQUE min _____

ROTATION SPEED min _____

FORECAST LIFE CYCLES min _____
 max _____

PAYLOAD

WORKING ENVIROMENT



FLUID TYPE

LUBRICATION

TREATMENT

Return with spring
 Single action normally Assists

SLOT POSITION

Clock wise Counter-clock wise

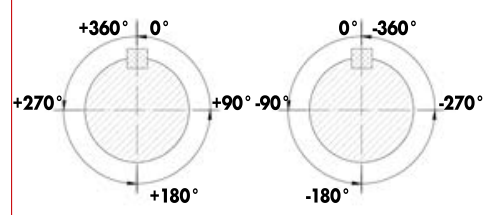

OPERATION

